

Positive Analog Feedback Compensates PT100 Transducer

This article reviews the basic characteristics of common temperature sensors, describes the RTD PT100 temperature transducer, and explains a simple analog approach for linearizing and conditioning the output of that device.

Temperature is one of the most measured physical parameters. Thermocouple and resistance temperature detector (RTD) sensors are adequate for most high-temperature measurements, but one should choose a sensor that has characteristics best suited for the application. Table 1 offers general guidelines for choosing a sensor.

Table 1. Sensor Attributes

Feature	Thermocouple	RTD
Response time	Better	
Maximum temperature	Higher	
Ruggedness	Better	
Cost efficiency	Better	
Accuracy		Better
Long-term stability		Better
Standardization		Better

RTDs offer high precision and an operating range of -200°C to $+850^{\circ}\text{C}$. They also have an electrical output that is easily transmitted, switched, displayed, recorded, and processed using suitable data-processing equipment. Because RTD resistance is proportional to temperature, applying a known current through the resistance produces an output voltage that increases with temperature. Knowledge of the exact relationship between resistance and temperature allows calculation of a given temperature.

The change in electrical resistance vs. temperature for a material is termed the "temperature coefficient of resistance" for that material. The temperature coefficient for most metals is positive, and for many pure metals is essentially constant over a large portion of the useful temperature range. Moreover, a resistance thermometer is the most stable, accurate, and linear device available for temperature measurement. The resistivity of metal used in an RTD (including platinum, copper, and nickel) depends on the range of temperature measurements desired.

The nominal resistance of a platinum RTD is 100Ω at 0° C. Though platinum RTDs are highly standardized, they conform to multiple standards that are not identical worldwide. Therefore, problems arise when an RTD built to one standard is used with an instrument designed to a different standard.

Table 2. Common Standards for Platinum RTDs*

Organization	Standard	ALPHA (α): Average Temperature Coefficient of Resistance (1/° C)	Nominal Resistance at 0° C (Ω)
British Standard	BS 1904: 1984	0.003850	100
Deutschen Institut für Normung	DIN 43760: 1980	0.003850	100
International Electrotechnical Commission	IEC 751: 1995 (Amend. 2)	0.00385055	100
Scientific Apparatus Manufacturers of America	SAMA RC-4-1966	0.003923	98.129
Japanese Standard	JIS C1604-1981	0.003916	100
American Society for Testing and Materials	ASTM E1137	0.00385055	100

*Sensing Devices, Inc. manufactures platinum RTDs to these thermometry standards.

Platinum's long-term stability, repeatability, fast response time, and wide temperature range make it a useful choice in many applications. As a result, platinum RTDs are recognized as the most reliable standard available for temperature measurement. The PT100 RTD is described by the following generic equation, which makes obvious a nonlinear relationship between temperature and resistance:

$$R_T = R_0(1 + AT + BT^2 + C(T-100)T^3)$$

where:

$$A = 3.9083 \text{ E-3}$$

$$B = -5.775 \text{ E-7}$$

$$C = -4.183 \text{ E-12 below } 0^\circ \text{ C, and zero above } 0^\circ \text{ C}$$

See **Table 3** for the corresponding data in tabular form.

Table 3. Resistance/Temperature Table for 385 Platinum, 100.0Ω at 0° C**

° C	0	1	2	3	4	5	6	7	8	9
-100	60.26									
-90	64.3	63.89	63.49	63.08	62.68	62.28	61.87	61.46	61.06	60.66
-80	68.32	67.92	67.52	67.12	66.72	66.31	65.91	65.51	65.1	64.7
-70	72.33	71.93	71.53	71.13	70.73	70.33	69.93	69.53	69.13	68.73
-60	76.33	75.93	75.53	75.13	74.73	74.33	73.93	73.53	73.13	72.73
-50	80.31	79.91	79.51	79.12	78.72	78.32	77.92	77.52	77.12	76.73
° C	0	1	2	3	4	5	6	7	8	9
-40	84.27	83.88	83.48	83.08	82.69	82.29	81.9	81.5	81.1	80.7
-30	88.22	87.83	87.43	87.04	86.64	86.25	85.85	85.46	85.06	84.67
-20	92.16	91.77	91.37	90.98	90.59	90.19	89.8	89.4	89.01	88.62
-10	96.09	95.69	95.3	94.91	94.52	94.12	93.73	93.34	92.95	92.55
0	100	99.61	99.22	98.83	98.44	98.04	97.65	97.26	96.87	96.48
° C	0	1	2	3	4	5	6	7	8	9
0	100	100.39	100.78	101.17	101.56	101.95	102.34	102.73	103.12	103.51
10	103.9	104.29	104.68	105.07	105.46	105.85	106.24	106.63	107.02	107.4
20	107.79	108.18	108.57	108.96	109.34	109.73	110.12	110.51	110.9	111.28
30	111.67	112.06	112.45	112.83	113.22	113.61	113.99	114.38	114.77	115.15
40	115.54	115.92	116.31	116.7	117.08	117.47	117.85	118.24	118.62	119.01
° C	0	1	2	3	4	5	6	7	8	9
50	119.4	119.78	120.16	120.55	120.93	121.32	121.7	122.09	122.47	122.86
60	123.24	123.62	124.01	124.39	124.77	125.16	125.54	125.92	126.31	126.69
70	127.07	127.45	127.84	128.22	128.6	128.98	129.36	129.75	130.13	130.51
80	130.89	131.27	131.66	132.04	132.42	132.8	133.18	133.56	133.94	134.32
90	134.7	135.08	135.46	135.84	136.22	136.6	136.98	137.36	137.74	138.12
° C	0	1	2	3	4	5	6	7	8	9
100	138.5	138.88	139.26	139.64	140.02	140.4	140.77	141.15	141.53	141.91
110	142.29	142.66	143.04	143.42	143.8	144.18	144.55	144.93	145.31	145.68
120	146.06	146.44	146.82	147.19	147.57	147.94	148.32	148.7	149.07	149.44
130	149.82	150.2	150.70	150.95	151.33	151.7	152.08	152.45	152.83	153.2
140	153.70	153.95	154.32	154.7	155.07	155.45	155.82	156.2	156.57	156.94
° C	0	1	2	3	4	5	6	7	8	9
150	157.32	157.69	170.06	170.44	170.81	159.18	159.56	159.93	160.3	160.67
160	161.04	161.42	161.79	162.16	162.53	162.9	163.28	163.65	164.02	164.39

170	164.76	165.13	165.5	165.88	166.24	166.62	166.99	167.32	167.73	168.1
180	168.47	168.84	169.21	169.70	169.95	170.32	170.68	171.05	171.42	171.79
190	172.16	172.53	172.9	173.27	173.64	174	174.37	174.74	175.11	175.48
° C	0	1	2	3	4	5	6	7	8	9
200	175.84									

**RTD PT100 table showing the relation between resistance and temperature.

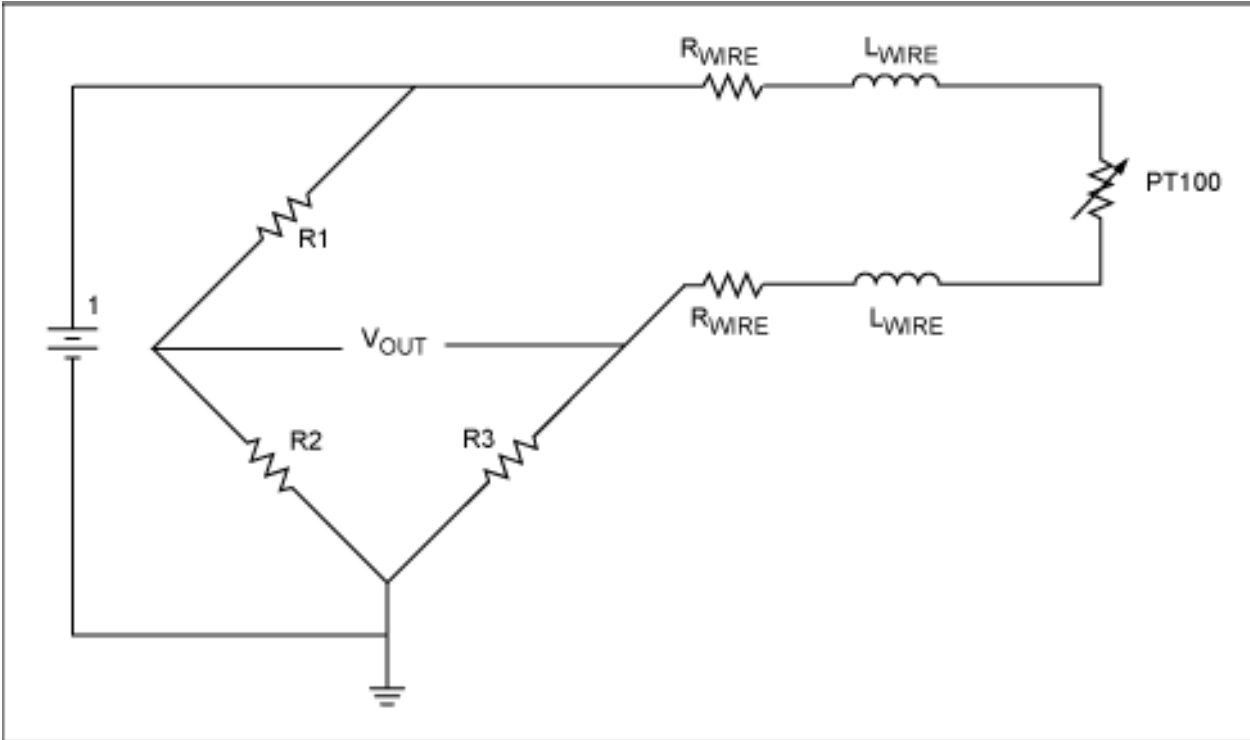

Figure 1. This two-wire connection affects measurement accuracy by adding resistance in series with the RTD.

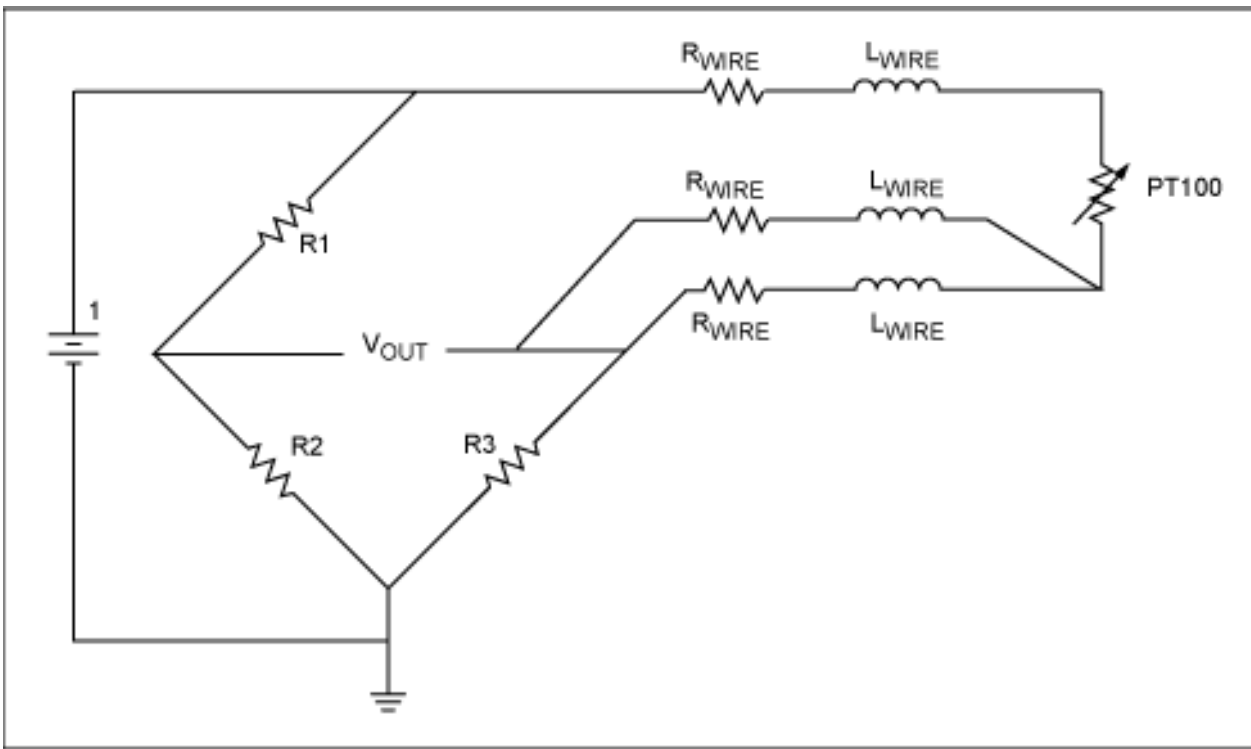

Figure 2. An additional third wire to the RTD allows compensation for the wire resistance. The only restriction is that the main connecting wires have the same characteristics.

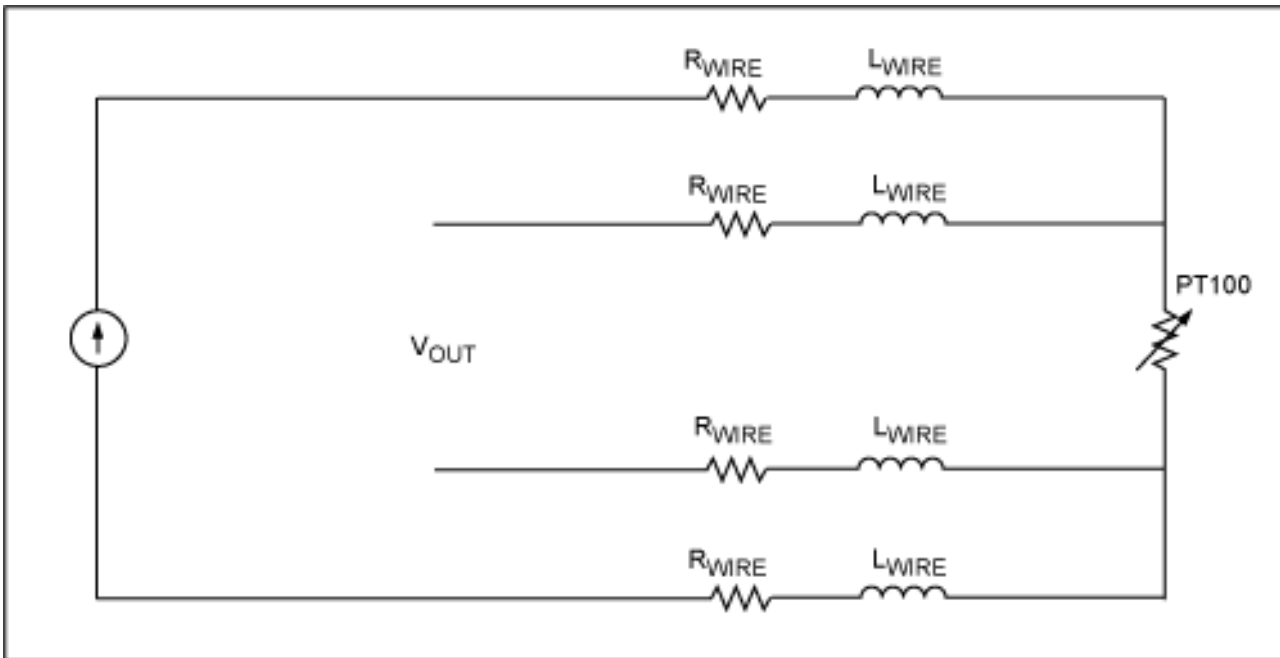

Figure 3. A four-wire approach enables Kelvin sensing, which eliminates the effect of voltage drops in the two connecting wires.

You can connect a PT100 RTD to the measuring application using two wires, three wires, or four wires (**Figures 1, 2, and 3**). Several analog and digital approaches are available for compensating a PT100 RTD for nonlinearity. Digital linearization, for instance, can be implemented with a lookup table or by implementing the previous generic equation.

A lookup table located in μP memory allows an application to convert (through interpolation) a

measured PT100 resistance to the corresponding linearized temperature. On the other hand, the previous generic equation offers a possibility of calculating temperature values directly, based on the actual measured RTD resistance.

A lookup table necessarily contains a limited number of resistance/temperature values, as dictated by the required accuracy and the amount of memory available. To calculate a specific temperature, you must first identify the two closest resistance values (those above and below the measured RTD value), and then interpolate between them.

Consider a measured resistance of 109.73Ω , for example. If the lookup table has a resolution of 10°C , the two closest values might be 107.79Ω (20°C) and 111.67Ω (30°C). Interpolation using these three values leads to:

$$\frac{(\text{measured value} - \text{closest lower value}) \times \text{resolution in } ^\circ\text{C} + \text{closest lower temperature}}{(\text{closest higher value} - \text{closest lower value})}$$

$$\frac{(109.73\Omega - 107.79\Omega) \times 10^\circ\text{C} + 20^\circ\text{C}}{(111.67\Omega - 107.79\Omega)}$$

This digital approach requires use of a microprocessor (μP), but the small circuit in **Figure 4** performs accurate linearity compensation using the analog approach. It provides outputs of 0.97V at -100°C and 2.97V at 200°C . It may be necessary to add gain adjustment (span) and a level shift (offset) to cover an output range of -100mV at -100°C to 200mV at 200°C , for example.

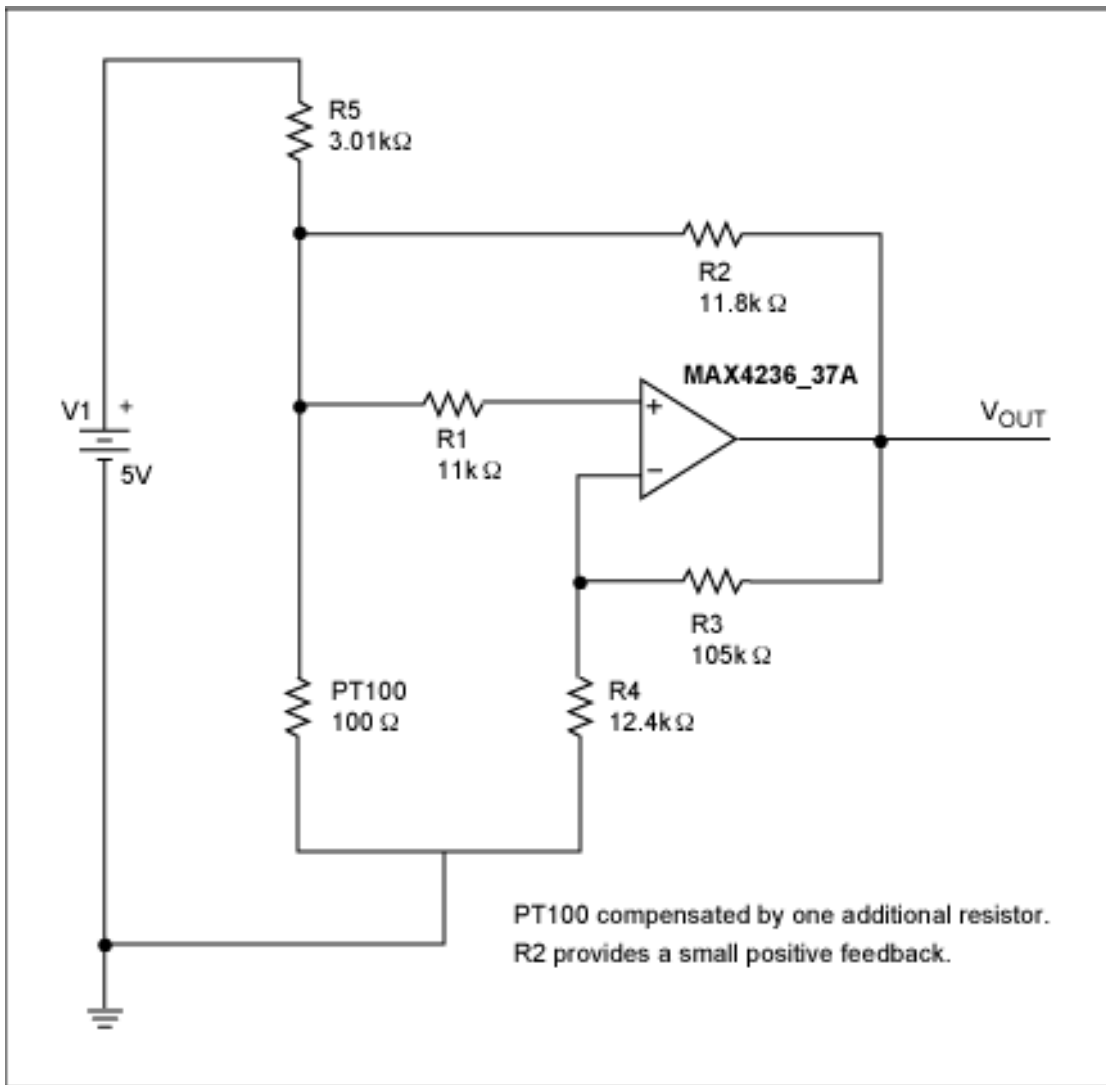

Figure 4. This analog circuit linearizes an RTD output.

The suggested way to compensate for nonlinearity in the PT100 element is to apply a small amount of positive feedback through R2. That feedback helps to linearize the transfer function by providing a slightly higher output at high PT100 values. The transfer function can easily be established by applying the superposition principle:

$$V+' = V1 \times \frac{R2||PT100}{R2||PT100 + R5}$$

$$V+'' = V_{OUT} \times \frac{R5||PT100}{R5||PT100 + R2}$$

$$V- = V_{OUT} \times \frac{R4}{R4 + R3}$$

$$V- = V+' + V+''$$

$$V_{OUT} \times \frac{R4}{R4 + R3} = V1 \times \frac{R2||PT100}{R2||PT100 + R5} = V_{OUT} \times \frac{R5||PT100}{R5||PT100 + R2}$$

$$V_{OUT} = \frac{V1 \times \frac{R2||PT100}{R2||PT100 + R5}}{\frac{R4}{R4 + R3} - \frac{R5||PT100}{R5||PT100 + R2}}$$

Figure 5 shows the raw PT100 output vs. a linear approximation of the form $y = ax + b$, and **Figure 6** shows a linearized version of the circuit output vs. the linear approximation. Each figure shows the calculated relationship between temperature and resistance compared to the output calculated from the Figure 4 circuit. The graphs of **Figures 7** and **8** illustrate the PT100 error before and after analog compensation.

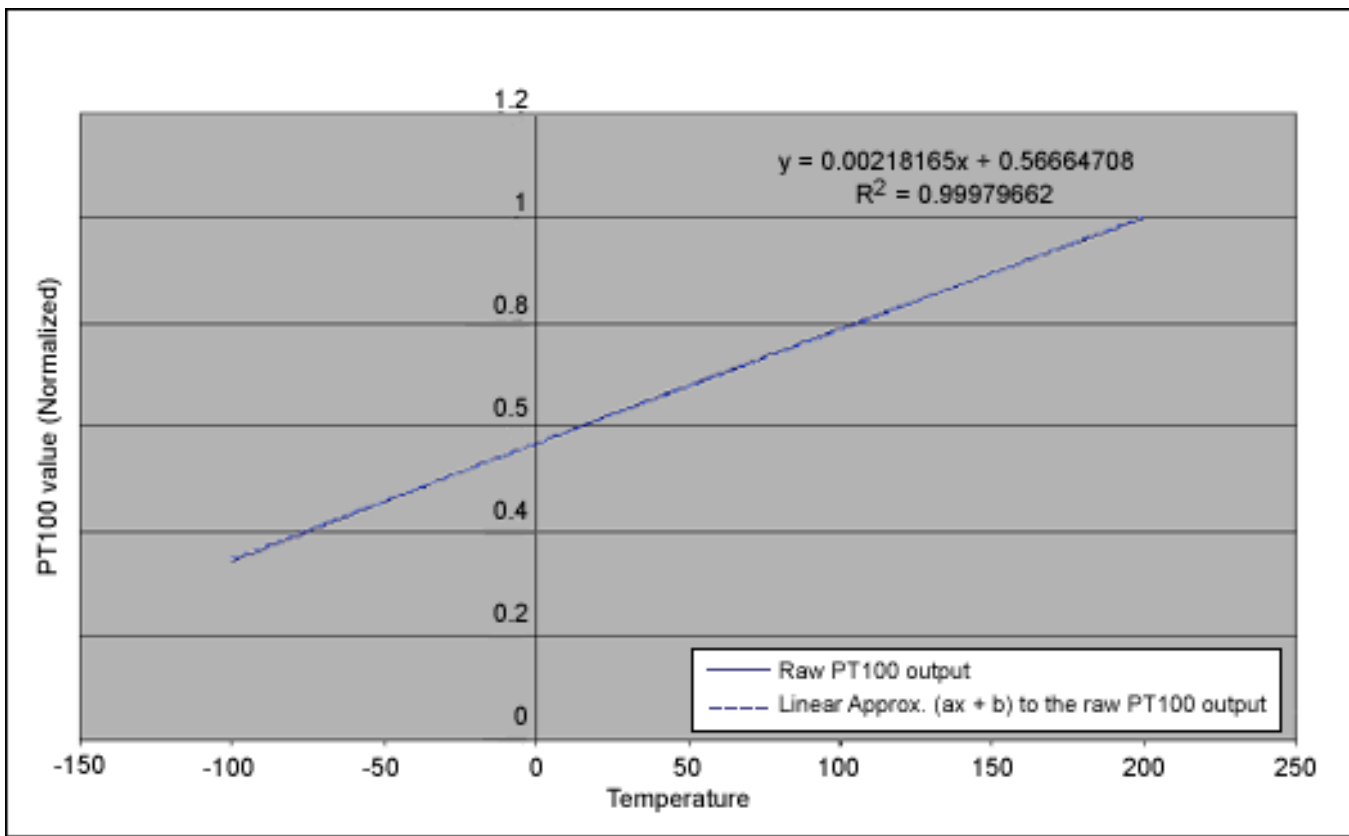

Figure 5. Raw output of a normalized PT100 vs. a linear approximation to that output.

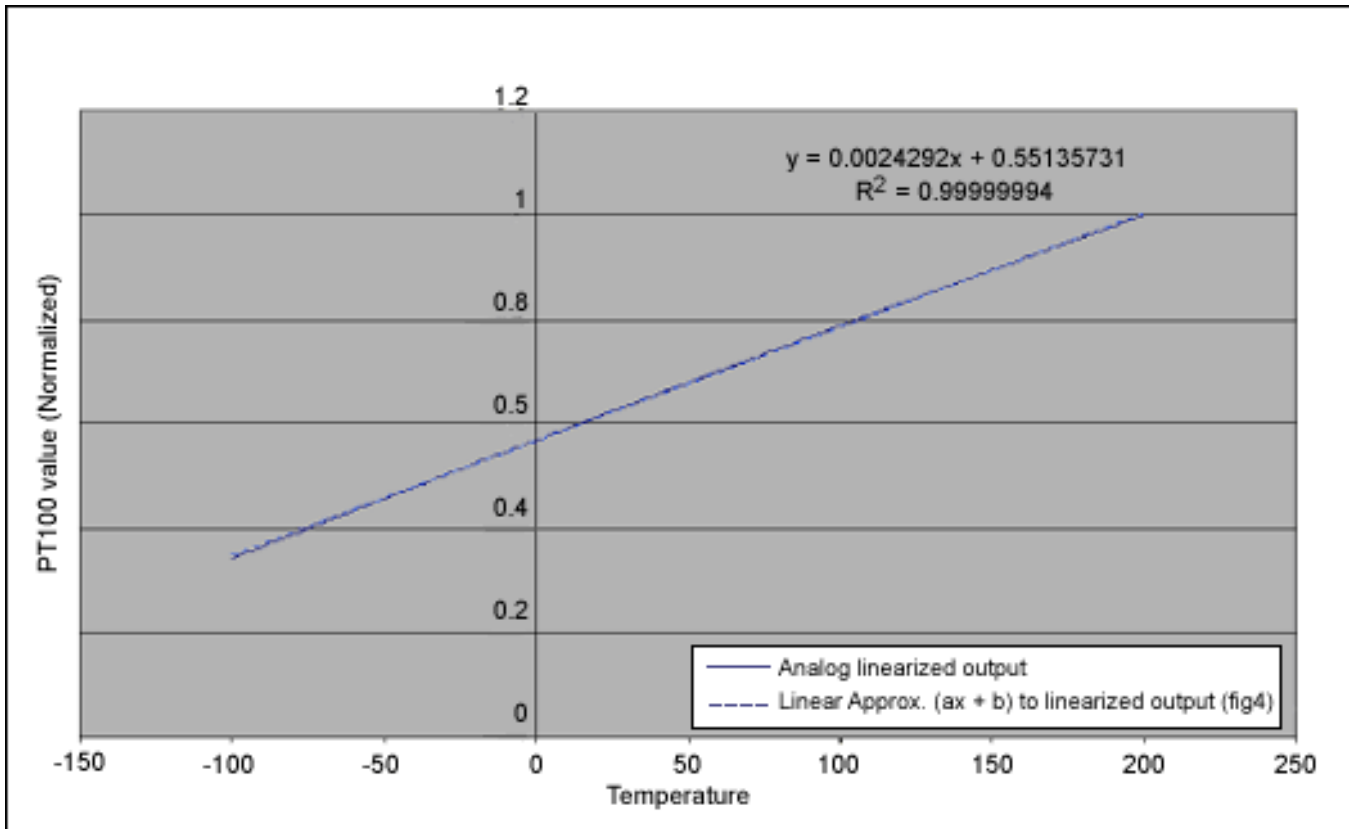

Figure 6. Analog-compensated output vs. a linear approximation to that output, showing the error after linearization.

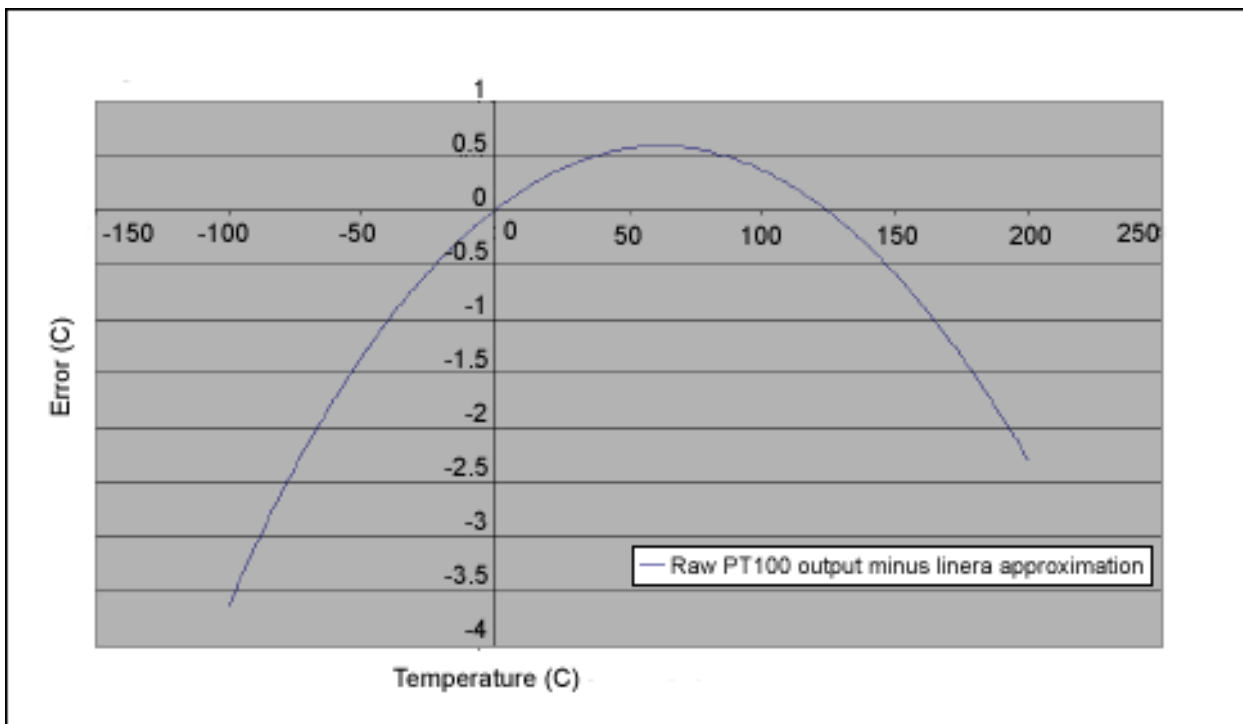

Figure 7. Normalized error, representing the deviation between raw PT100 output, and a linear approximation of the PT100 relation between temperature and resistance.

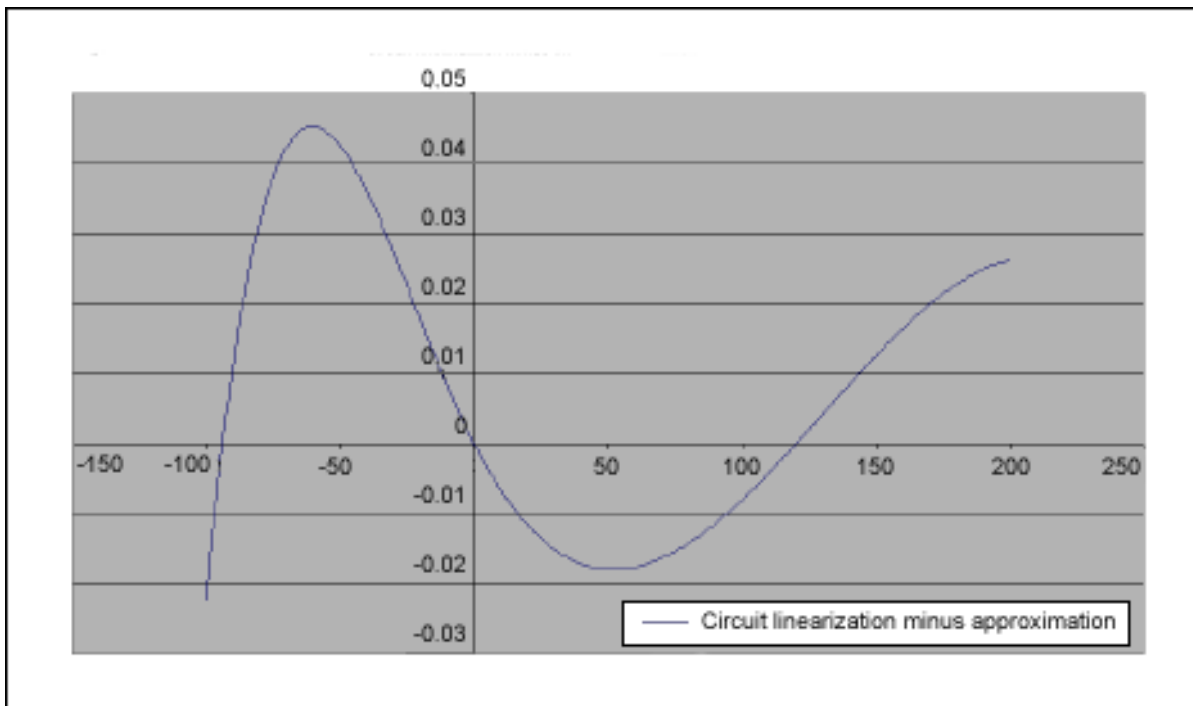

Figure 8. Normalized error, representing the deviation between the linearized output of Figure 4 and a linear approximation of the PT100 relation between temperature and resistance. Normalizing the curves of Figures 7 and 8 makes it easy to assess the performance of the Figure 4 circuit.

When calibrating an analog thermometer, it is always preferable to minimize the need for adjustments and control measurements during production and calibration. Normally, it is best to adjust only the offset and span at two PT100 values. That approach, however, requires a linear relationship between PT100 resistance and temperature, which is not the case.

The exercise above shows that analog compensation can reduce PT100 errors by a factor of approximately 80, assuming the transfer function exhibits a linear correlation between the PT100 value and the measured temperature. Additionally, low power dissipation in the PT100 (0.2mW to 0.6mW) minimizes self-heating. Thus, PT100 signals linearized using the analog approach allow an easy interface to $\pm 200\text{mV}$ panel meters, for example, without additional software overhead.

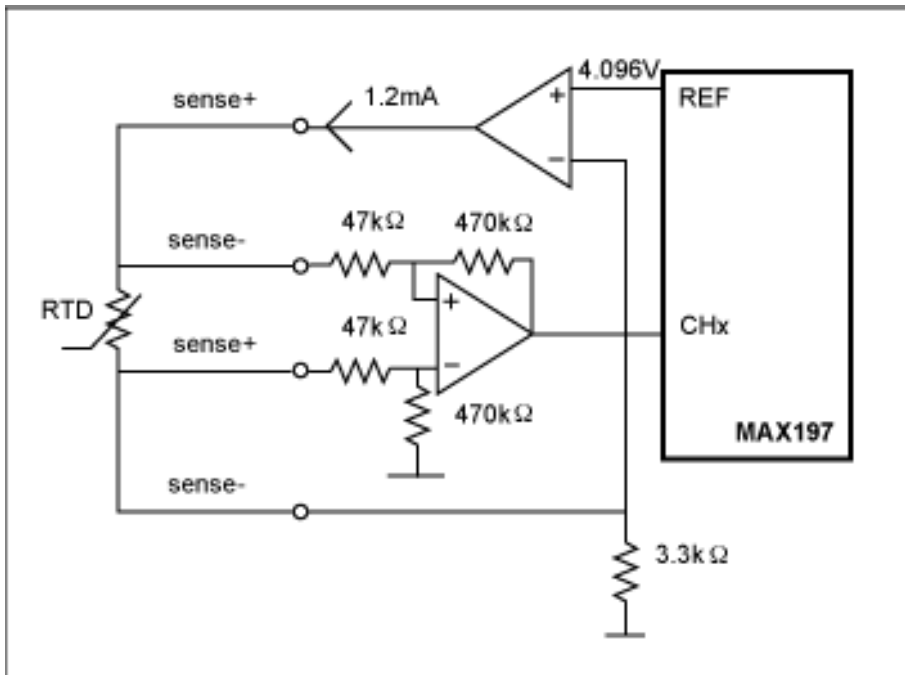

Figure 9. Digital approach: An ADC converts the RTD output to digital under control of a μP . Then, the μP calculates the corresponding temperature using a lookup table.

An example of the digital approach (,b>Figure 9) involves an RTD, a difference amplifier, a current source, and an ADC controlled by a μP (not shown). A temperature measurement is accomplished by driving a current of 1mA to 2mA through the sensor and measuring the resulting voltage drop across it. Higher currents cause higher power dissipation in the sensor, which in turn causes measurement errors due to self-heating. An internal 4.096V reference simplifies the generation of excitation current for the sensor.

To prevent wire resistance from affecting measurement accuracy, four separate wires connect the RTD to the differential amplifier. Because the sense wires connect to the amplifier's high-impedance inputs, they have very low current and virtually no voltage drop. The 4096mV reference and 3.3k Ω feedback resistor sets the excitation current to approximately $4096\text{mV}/3.3\text{k}\Omega = 1.24\text{mA}$. Thus, driving the ADC and current source with the same reference voltage produces a ratiometric measurement in which reference drift does not influence the conversion result.

By configuring the MAX197 for an input range of 0V to 5V and setting the differential amplifier for a gain of 10, you can measure resistance values up to 400 Ω , which represents about +800° C. The μP can use a lookup table to linearize the sensor signal. To calibrate the system, replace the RTD with two precision resistors (100 Ω for 0° C, and 300 Ω or higher for full span) and store the conversion results.

More Information

MAX197: [QuickView](#) -- [Full \(PDF\) Data Sheet](#) -- [Free Samples](#)

MAX4236: [QuickView](#) -- [Full \(PDF\) Data Sheet](#) -- [Free Samples](#)

MAX4237: [QuickView](#) -- [Full \(PDF\) Data Sheet](#) -- [Free Samples](#)